



**DOUGLAS**  
WASHING AND SANITIZING SYSTEMS

## BUYERS GUIDE



# CONTENTS

---

Who We Are? .....	3
What Makes Us Unique? .....	4
Industries Served .....	7
Containers We Wash .....	8
Pan & Bucket Washer .....	10
Rack Washer .....	12
Scale Parts Washer .....	14
Rack Washer .....	16
Bin & Tote Washer .....	18
Belt Washer .....	20
COP Washer .....	21
Tunnel Washer .....	22
Smoke Truck Washer .....	24
Specialty Washer .....	25



# WHO WE ARE?

---

DOUGMAC is a performance-driven team of experienced manufacturing professionals. A cooperative company with a single purpose - a unified, strong commitment to serving our customers. Most importantly, we are a dynamic company committed to delivering on our core values in all that we do!

DOUGMAC utilizes a team-driven approach that resembles a fully automated factory. Our professional manufacturing experts work together to bring every project to the finish line with consistent winning results, on-time and on budget.

The keys to DOUGMAC are a culture of excellence in project execution, innovative design, operational excellence, and quality; emphasizing customer and employee satisfaction.

At DOUGMAC, we understand training, communication, teamwork, and world-class performance standards are essential to helping our clients successfully meet and exceed their goals.



**“ We strive to make our products better, satisfy our customers, keep our employees happier and build our company to be the best it can be ”**



## WHAT MAKES US UNIQUE?



Same Day Shipping  
on Machines Parts



Installation and  
Demonstration



Machine  
Upgrades



In-House Design and  
Engineered



Machine Assessment  
And Audits



Up Time  
Maintenance Kits



## The 5e Standard:



### EFFICIENT

Maximum productivity with minimum wasted effort



### EFFECTIVE

Consistent results that can be tracked



### EASY TO USE

Straight forward and simple to set up, operate & maintain



### ECONOMICAL

Increase value by operating resources to save on time, money & effort spent



### ECO-FRIENDLY

Conserves resources to not harm the environment

# OUR VISION

To provide the highest value to our customers, suppliers, employees, and shareholders as we deliver quality Automated Washing and Sanitizing Solutions to targeted industries across the globe.

We deliver operational customer service excellence in every corner of our company, while bringing the right solutions in addressing customers specific needs.

Our long-term strategies and short-term actions are grounded by our collective set of core values, strong commitment to a safe workplace; and shared by each and every employee.

In the end, our Vision is to be the leading global manufacturing company most admired for its people, products, partnerships, and performance while being recognized as the easiest manufacturer for customers to do business with.

# OUR MISSION

“To be the Leading Global Innovator & Manufacturer of Automated Washing and Sanitizing Solutions! Fortified with a commitment to provide superior products at a fair price, delivering them on schedule while offering the best customer service in our industry.”

# INDUSTRIES SERVED

We provide custom cleaning solutions for a variety of industries. We are trusted by our customers to deliver tailored solutions that maximize productivity and increase the shelf life of equipment, tools, and utensils. With a high referral rate and repeat customers, it's a proven formula for success.



SNACK FOODS



BAKERY



PREPARED FOODS



SUPERMARKET



FOOD SERVICE



MEATS



INGREDIENTS



PRODUCE



CONFECTIONARY



PET FOOD



POULTRY



NUTRACEUTICALS



DISTRIBUTION



SEAFOOD







## TYPICAL CONTAINERS

- Roasting Pans
- Scale Buckets
- Screens
- Shipping Cabinets
- Shipping Baskets
- Shopping Carts
- Smoke Screens
- Smoke Trucks
- Smoke Sticks
- Strap Pans
- Industrial Parts
- Ingredient Bins
- Lids
- Lugs
- Steam Table Pans
- Totes
- Transport Racks
- Transport Baskets
- Trays
- Troughs /Tubs
- Utensils
- Vats
- V-Mags
- Weight Buckets
- Wire Baskets
- Pallet
- Proofing Boards
- Machine Parts
- Mixing Bowls
- Moulds
- Muffin Pans
- Oven Racks
- Pails
- Pallets
- Cake Moulds
- Cake Pans
- Candy Moulds
- Cooling Racks
- Crates
- Donut Screens
- Feed Buckets
- Field Bins
- Fish Crates
- Ham Moulds
- Hatchery Baskets
- Agriculture Bins
- Bagel Boards
- Baguette Screens
- Barrels / Bins
- Bread Baskets
- Bread / Loaf Pans
- Buckets
- Buggies
- Bundt Pans
- Bun/Sheet Pans

# PAN & BUCKET WASHER

A complete line of washing systems for smaller batch quantities. Choose from Lift-Door, Split Door, Pass-through, and/or Corner Pass-through models with capacities of 10, 20, or 36 pans. Each can may be equipped with standard or custom design wash racks to process several types of containers. With pre-program wash cycles of just 4, 6, or 8 minutes for varying soil conditions, clean-up is quick and efficient.



**Split Door**



**Pass-Through**



**Lift Door**

# PRODUCT LINE

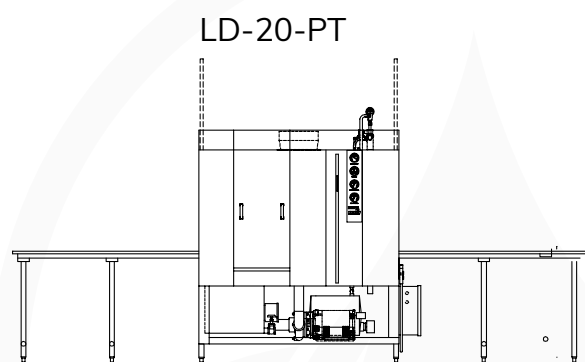
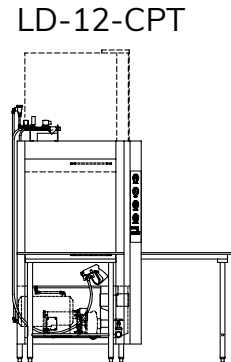
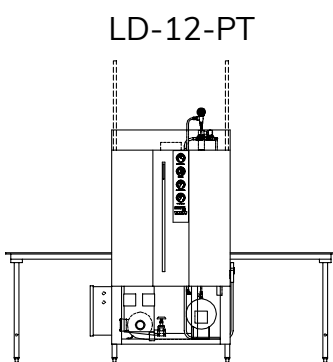
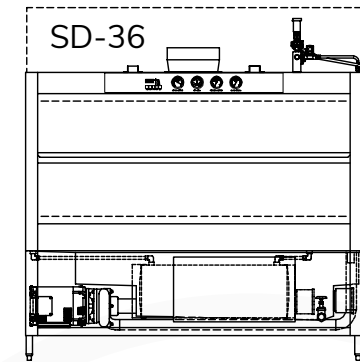
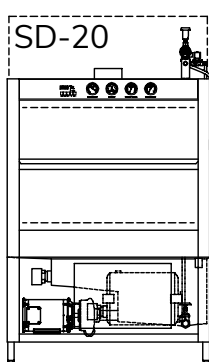
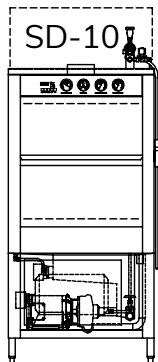
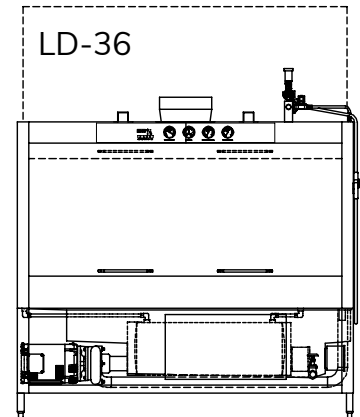
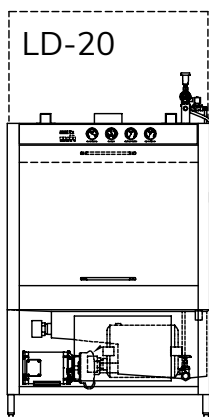
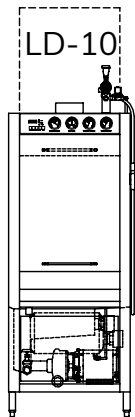

# STANDARD FEATURES

- Quality Stainless-Steel Construction
- Recirculating Wash Tank
- Digital Control Center
- Processes Up to 10 Batches an Hour
- Temperature and Pressure Gauges
- Standard Self-Contained Water Heating
- Easy to Clean System Design
- Front or Side Loading
- Lift or Split Door Design Options
- Pass-thru Capabilities

# RACK WASHER

Douglas Rack Washing Systems are available in a variety of styles and capacities. Choose from front or rear mounted pump with high volume cycles designs. Some modules can be equipped with a second door for pass-thru operation. Each module utilizes standard or custom wash racks design to hold multiple types of containers.



# PRODUCT LINE

1536-N

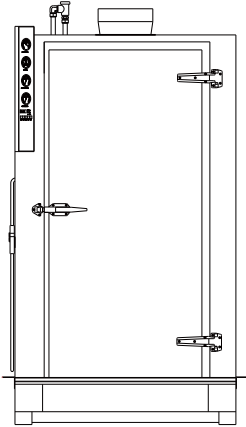

2554-B

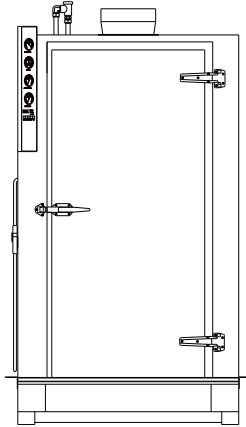

2554-N

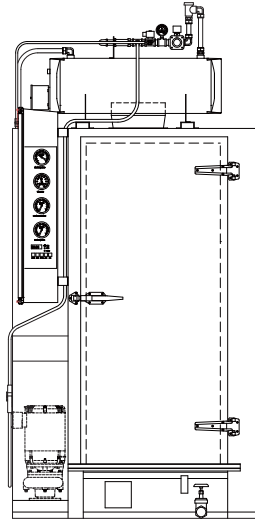

1536-N

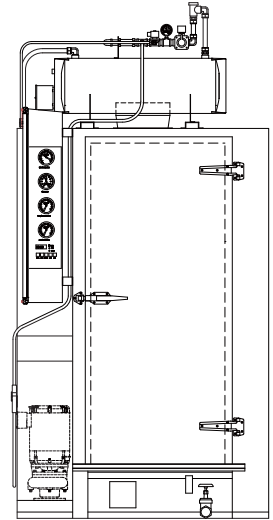

3072

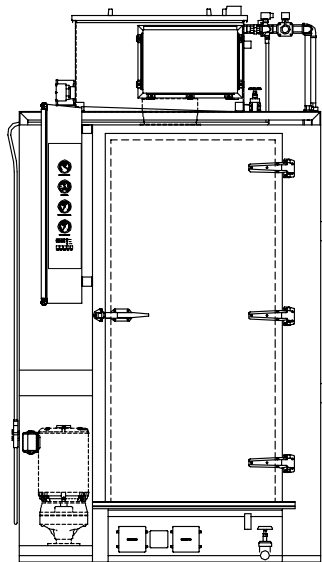

2566

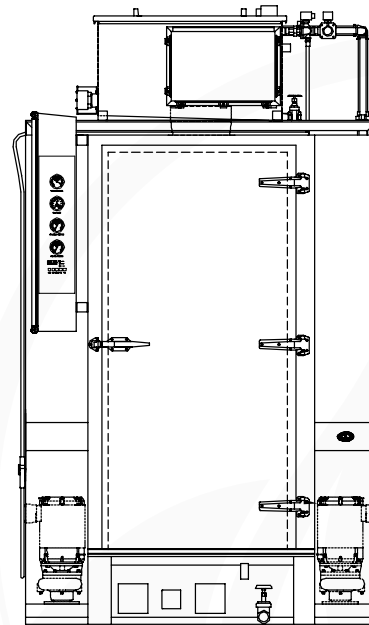

## STANDARD FEATURES

- Rugged stainless steel Construction
- Easy to Clean and Sanitize Design
- Water Saving Wash Tank
- Sanitizing Rinse Tank
- Self-Contained Water Heating

- Automatic Water Levels
- Digital Control and Information Center
- High Volume Processing Speed
- Powerful Wash System
- Customizable Easy Load Features

# SCALE PARTS WASHER

Developed in corporation with Manufacturers of multi-head weighers, Douglas Scale Part Washing Systems are designed to quickly and efficiently clean buckets, weigh hoppers, chutes and feeder pans. Specialized wash racks can be loaded at the weigh station and transported to the washer for easy cleaning. Racks are available for all types and sizes of scales and are designed to protect the during cleaning extending their over all life.



# PRODUCT LINE

---

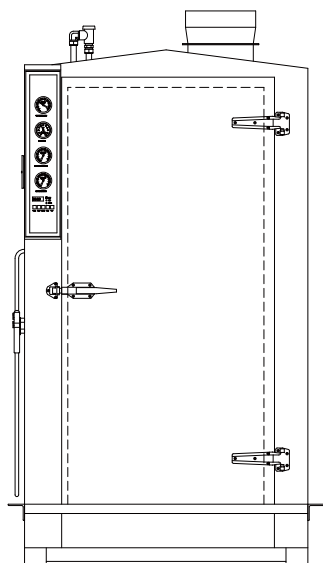

1536-SPW

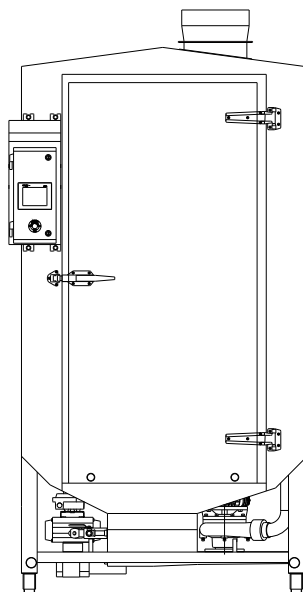

2554-SPW

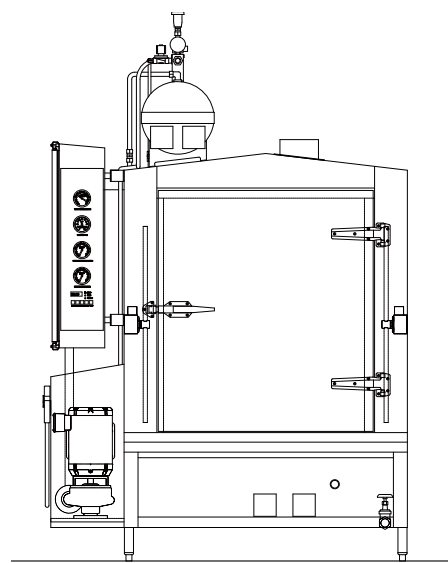

HD-12-SPW

## STANDARD FEATURES

---

- Rugged stainless steel Construction
- Easy to Clean and Sanitize Design
- Sanitary Slopped Roof
- Water Saving Wash Tank
- Sanitizing Rinse Tank
- Self-Contained Water Heating
- Automatic Water Levels
- Digital Control and Information Center
- High Volume Processing Speed
- Customizable Easy Load Features

# RACK WASHER

Douglas Custom Racks are constructed of Stainless Steel and are specially designed to hold a wide variety of containers. Sizes and Capacities are dependent on the available wash zone, which is specific to a particular model. Each custom rack is designed to hold containers in the proper position of spray patterns, to maximize cleaning effectiveness and to drain properly. Wash Racks are specifically designed to fit your need maximize your cleaning potential.





# SCALE PARTS RACK

---



# RACK INSERTS

---



# RACKS & INSERTS ARE CUSTOMIZABLE

---

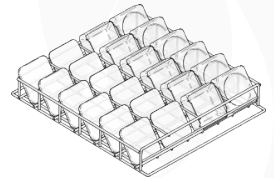
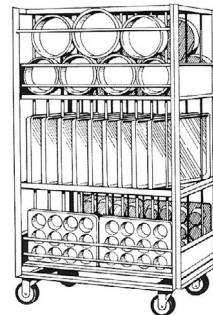
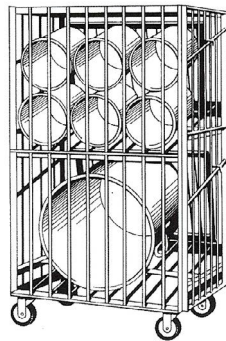
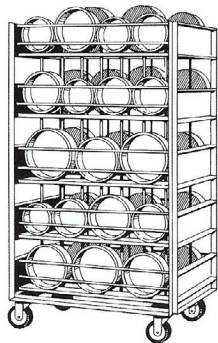
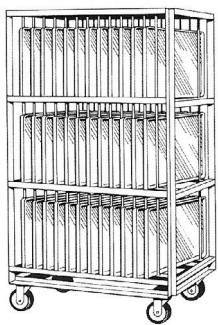

# BIN & TOTE WASHER

Experience a reduction in cleaning time and resources with small batch configuration for large volume containers. Clean many different vat, bin, vemag carts and buggy types with models specific to general food processing, meat, and dairy applications. Models clean up to two containers simultaneously and are suitable for wet or dry areas. Each can be equipped with standard or custom designed wash racks to process several types of containers. With programmed, pre-wash and wash cycles which are adjustable depending on the model for varying soil conditions, clean-up is quick and economical.



# PRODUCT LINE

VBW-1000-E

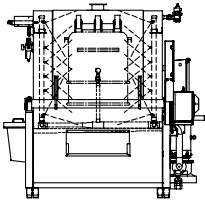

VBW-1000

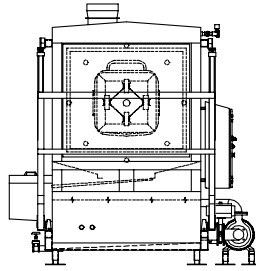

VBW-2000

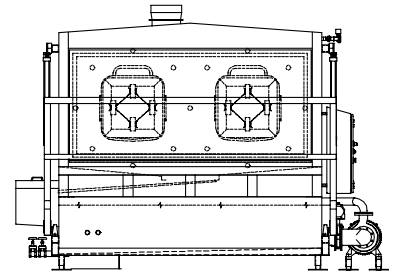

BW-1000-E

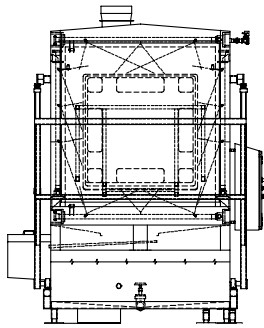

BW-1000-C

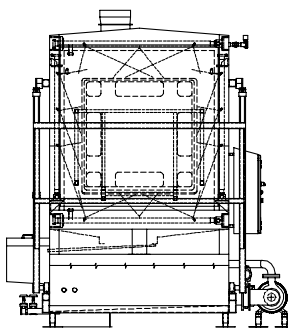

BW-1000-C-180

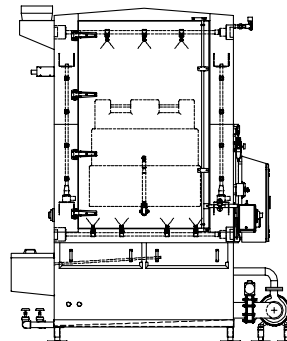

BW-2000-E

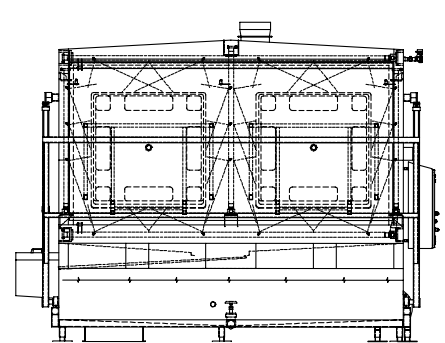

BW-2000-C

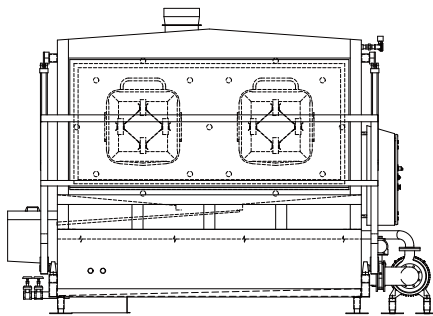

DVBW-1000-C

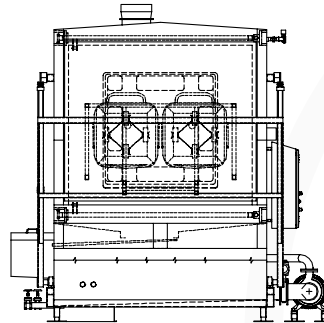

DVBW-2000-C

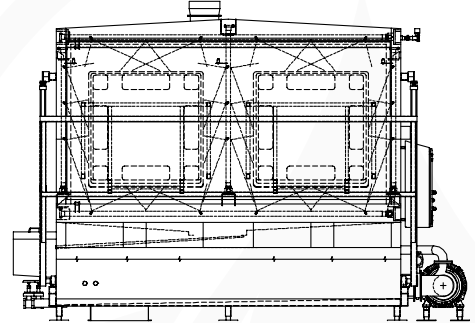

## STANDARD FEATURES

- Rugged Stainless Steel Construction
- Thermostatically Controlled Temperatures
- External Filter System
- Wash Down Duty Motor
- Adjustable Cycle Times
- Door Operated by Hydraulic Cylinders
- Automatic Rinse Diverter

# BELT WASHER

Designed for maximum shearing action and cleaning effectiveness, the rotating spray head cuts and removes stubborn soils from both the top and the bottom in one pass. The complete system comes with a portable cart that allows you to move from one belt to another for quick clean up. Consider an optional “Air Blast” blower with portable air knives to aid in drying, an optional catch pan to collect water for convenient routing to drain and an optional Linear Spray Head for solid belt applications.



## PRODUCT LINE

C-LH

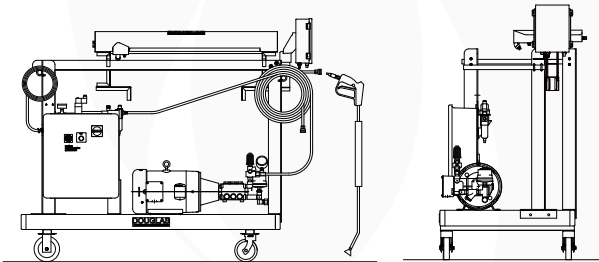

C-RH

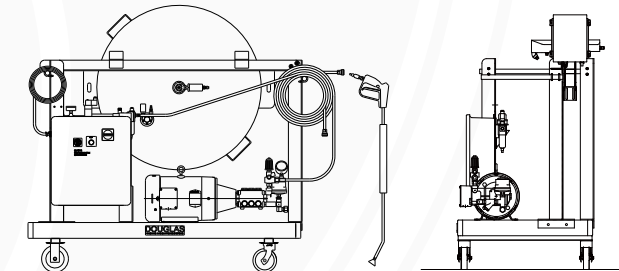

## STANDARD FEATURES

- Clean Plastic, Rubber or Metal Belts
- Speed and Pressure Adjustment
- Uses Just 3 to 4 GPM at 1500 to 2000 PSI
- Cleans Without Degreasers or Caustic
- Portable Spray Heads and Cart
- UL/CSA/CE Approved Control Panel

# COP WASHER

Clean Out of Place Washers are designed to aid in the cleaning of machine parts, valves and tubes in a recirculating wash tank that provides continuous, turbulent, jet action. This controlled action is ideal for cleaning irregular shaped parts that tend to have surfaces that are difficult to reach with conventional spray patterns.



## PRODUCT LINE

COP-48

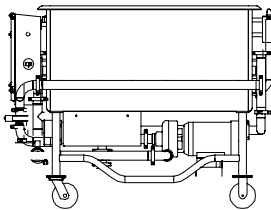

COP-72

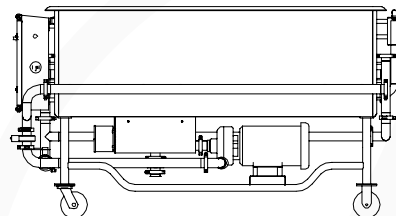

COP-96

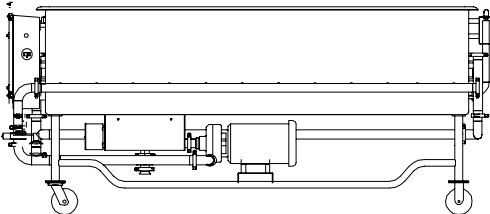

COP-120

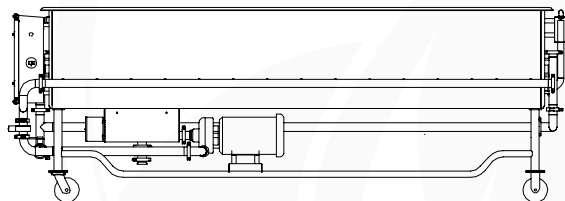

## STANDARD FEATURES

- High Quality Stainless Steel Construction
- Multiple Turbulent Patterns
- Adjustable Cycle Time
- Side and End Jets
- Ease of Cleaning Design
- Optional Parts Baskets
- Customizable Sizes
- Automatic Temperature Control
- Caustic Supported
- Steam or Electric Booster Heating

# TUNNEL WASHER

Douglas tunnel washers are fully customizable for continuous processing of items at high volume capacity, and the ability to process the broadest range of applications. Select from any heating configurations, single or multiple lane designs, and options for manual loading, in-line production or automated material handling. Suitable for wet or dry areas, the modular construction with flexible configurations allows for variable washing capacities.



# PRODUCT LINE

Recirculating Wash

Recirculating Rinse

Sanitizing Rinse

Blow off



## Space Saver

WR-1500

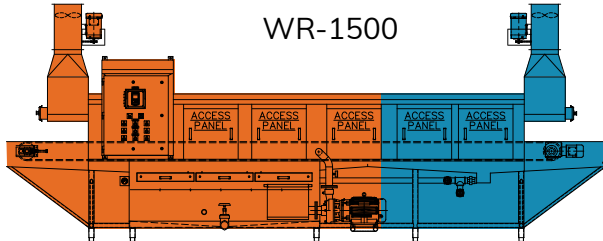

WRBO-1500

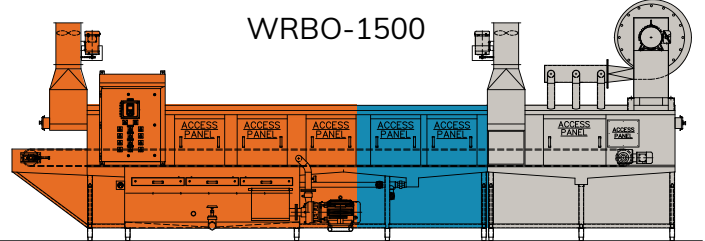

## Water Saver

WR-2000

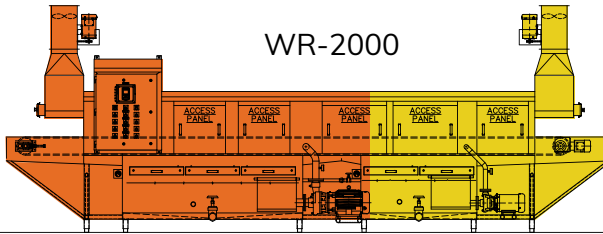

WRBO-2000

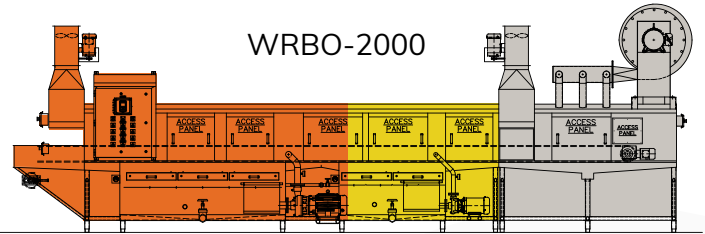

## Water Miser

WR-2500

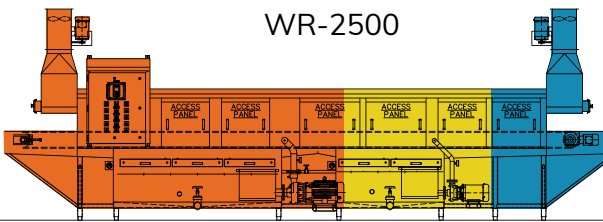

WRBO-2500

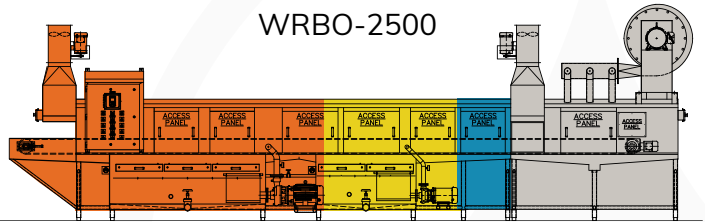

# FEATURES

- Quality Stainless-Steel Construction
- Vertical or Horizontal Loads
- Single or Two-Lane
- Space-Saving or Water-Saving Design
- In-line or Off-Line Use
- Exterior Filter Screens
- Load / Unload Tabling
- Easy Access Side Panel
- Automatic Fill / Low Water Protection
- Reversible A.C. Variable Speed Drive

# SMOKE TRUCK WASHER

These pit-mounted, specialty machines are designed to meet the harsh demands of the meat and poultry industry. Extra heavy duty construction combined with wash-down duty motors, stainless steel nozzles, fittings and pumps, allow the equipment to be used with caustic detergents to remove the most stubborn protein soils. An innovative automatic rinse diverter system conserves expensive detergents and significantly reduces operating costs.

## PRODUCT LINE

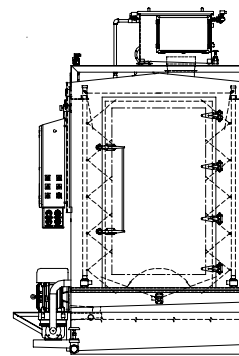

STW-1000

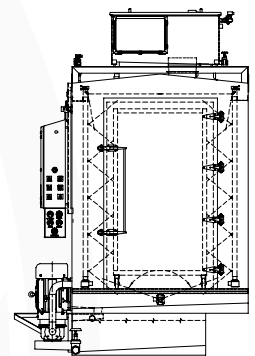

STW-2000

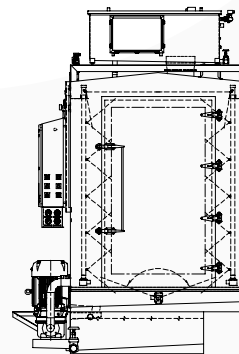

STW-3000

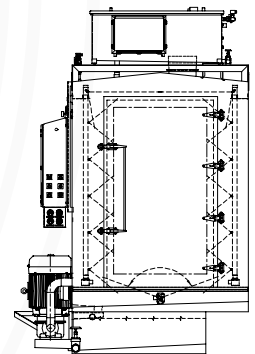

STW-4000

## STANDARD FEATURES

- High Quality Stainless-Steel Construction
- High Efficiency Motor
- Sanitizing Rinse Tank
- Automatic Water Level Controls
- Digital Control Center
- High Processing Speed
- Pass-thru Option
- Sanitary Sloped Roof
- Easy to Clean System Design



# SPECIALTY WASHER

Sometimes clients request a custom designed washing solution to match their unique requirements. This can lead to new models and sometimes to serving new industries. When a standard model doesn't match your needs, rely on us to custom design a solution!



IBC-1000



1536-FBW



GCW-1





## Warranty

Due to our many custom options, we quote based on your desired system and application. Our systems comes with a one year warranty or an additional year extended warranty for purchase. This is based upon 10% of the system cost.



## Installation

Installation is critical in maximizing safe production, reliability and minimizing life cycle costs. Proper installation insures minimal downtime, product quality reducing defects and high operating costs. We provide equipment installation and demonstrations, as well as wash tests and assuring proper production.



## Service & Parts

Our service and parts department is well prepared with uptime kits and carries a full range of parts to support your specific machines at any time. Allowing you to purchase the correct part and have it ship immediately to minimize downtime. Special System Uptime Kits are available ensuring you have the parts on hand and are at a special rate.



## Machine Assessment

Reliability and safety are the most important requirements for industrial machinery to ensure smooth manufacturing processes. With our comprehensive audit, risk potentials are identified early on and downtime rates are reduced. Our Technicians will advise the best options to keep or improve your systems production, assuring maximum efficiency.



# **DOUGLAS**

WASHING AND SANITIZING SYSTEMS

4500 110TH AVE N,  
CLEARWATER, FL 33762  
(727) 461-3477

Fax:(727)449-0029  
info@dougmac.com  
**www.DougMac.com**